

# LHCR Architecture

# Overview

- A repository containing the Logical requirements for the Technical Capabilities and the expected information flows and adherence to standards.
- A series of views showing the realization of the logical views by each LHCR
- Allow NHS-D/E to understand the LHCR architectures for realizing the technical requirement
- Allow NHS-D/E to identify capability gaps
- Allow the validation of the designs against use cases
- Understand the degree to which open standards have been used

# Roadmap 1

Phase	Task Title	Task Description	Effort	Sprint
Discovery	Understand all 23 LHCR TCs	Determine which of the 23 TC are suitable for architectural modelling, and are mature enough. Ensure that there is enough understanding of how the TC is going to operate including informal architectural designs.	3	
	Agree Capability Framework	Identify the overarching capability framework which is can act as context for constructing the LHCR architecture and ensuring that it is coherent with other on going architecture work.	1	
	Identify Relevant National Capabilities	Identify the relevant national and external capabilities that are have interactions with LHCR TCs	2	
	Agree Architecture Governance Process	Agree the processes and roles for developing the architecture, ownership of models, change process, review and approval.	3	
	Identify existing models.	Identify existing models that are relevant for the development of the LHCR architecture e.g. IIA and BFA	2	

# Roadmap 2

Phase	Task Title	Task Description	Effort	Sprint
Preparation	Prioritise Views	Determine which are the priority view to produce.	1	
	Create Modelling Framework	Create the framework in the tool that will be used to create the architecture. Metamodel, folder structure, library elements, templates.	1	
	Determine Use Cases	Determine the Use Cases that will be used to validate the architecture.	2	

# Roadmap 3

Phase	Task Title	Task Description	Effort	Sprint
Modelling	Create High Level Scoping Model	Create the high level model.	2	
	Create Logical Component Views for Priority TCs	Assume 6. Create the views for the Prioritised TCs or hybrid views of several TCs	10	
	Create Information Exchange Requirements View (Table)	Perform an information exchange requirement analysis determining the information exchanges and the information items which are conveyed.	2	
	Create Information Model	Consolidate all the information items from the logical views into an information model.		
	Create Use Case Views	Assume 3. Create the use case views that shall validate the TC architecture against real scenarios.	3	

# LHCR Architecture Meta-model

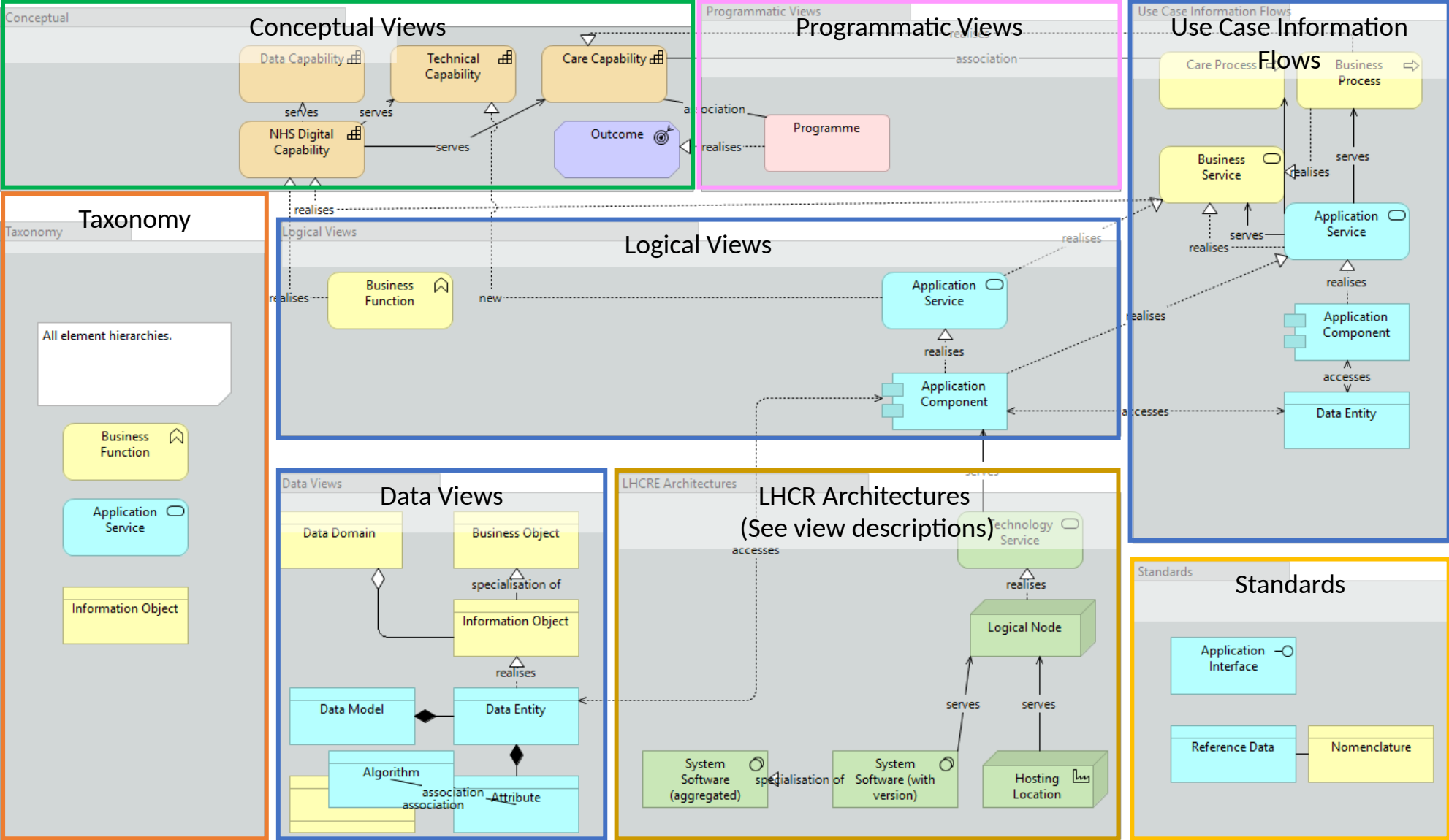

# Models in Abacus

# LHCR Architecture Framework

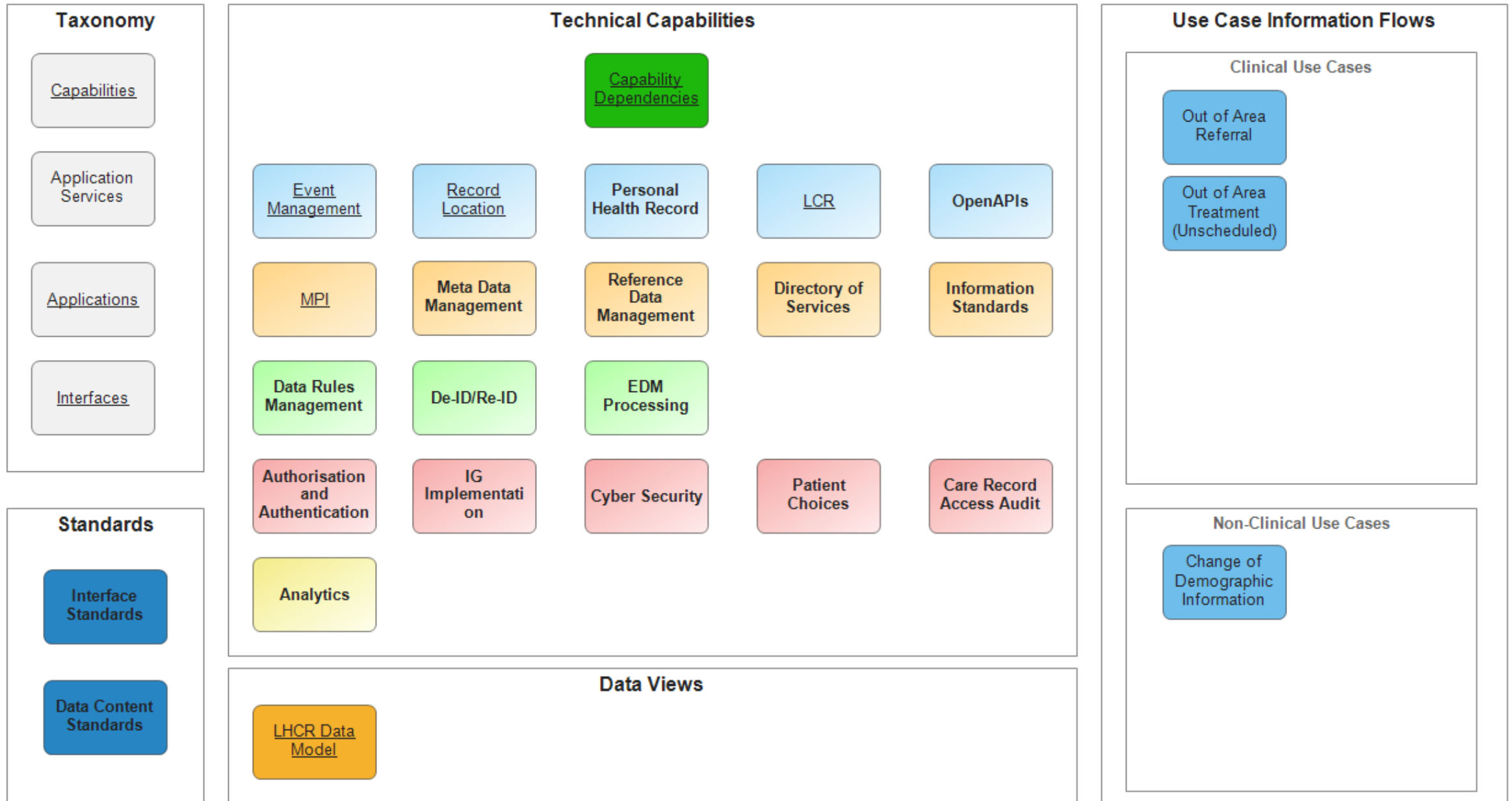

## Taxonomy

Capabilities

Application Services

Applications

Interfaces

## Standards

Interface Standards

Data Content Standards

## Technical Capabilities

Capability Dependencies

Event Management

Record Location

Personal Health Record

LCR

OpenAPIs

MPI

Meta Data Management

Reference Data Management

Directory of Services

Information Standards

Data Rules Management

De-ID/Re-ID

EDM Processing

Authorisation and Authentication

IG Implementation

Cyber Security

Patient Choices

Care Record Access Audit

Analytics

## Data Views

LHCR Data Model

## Use Case Information Flows

### Clinical Use Cases

Out of Area Referral

Out of Area Treatment (Unscheduled)

### Non-Clinical Use Cases

Change of Demographic Information

# Capability Dependencies

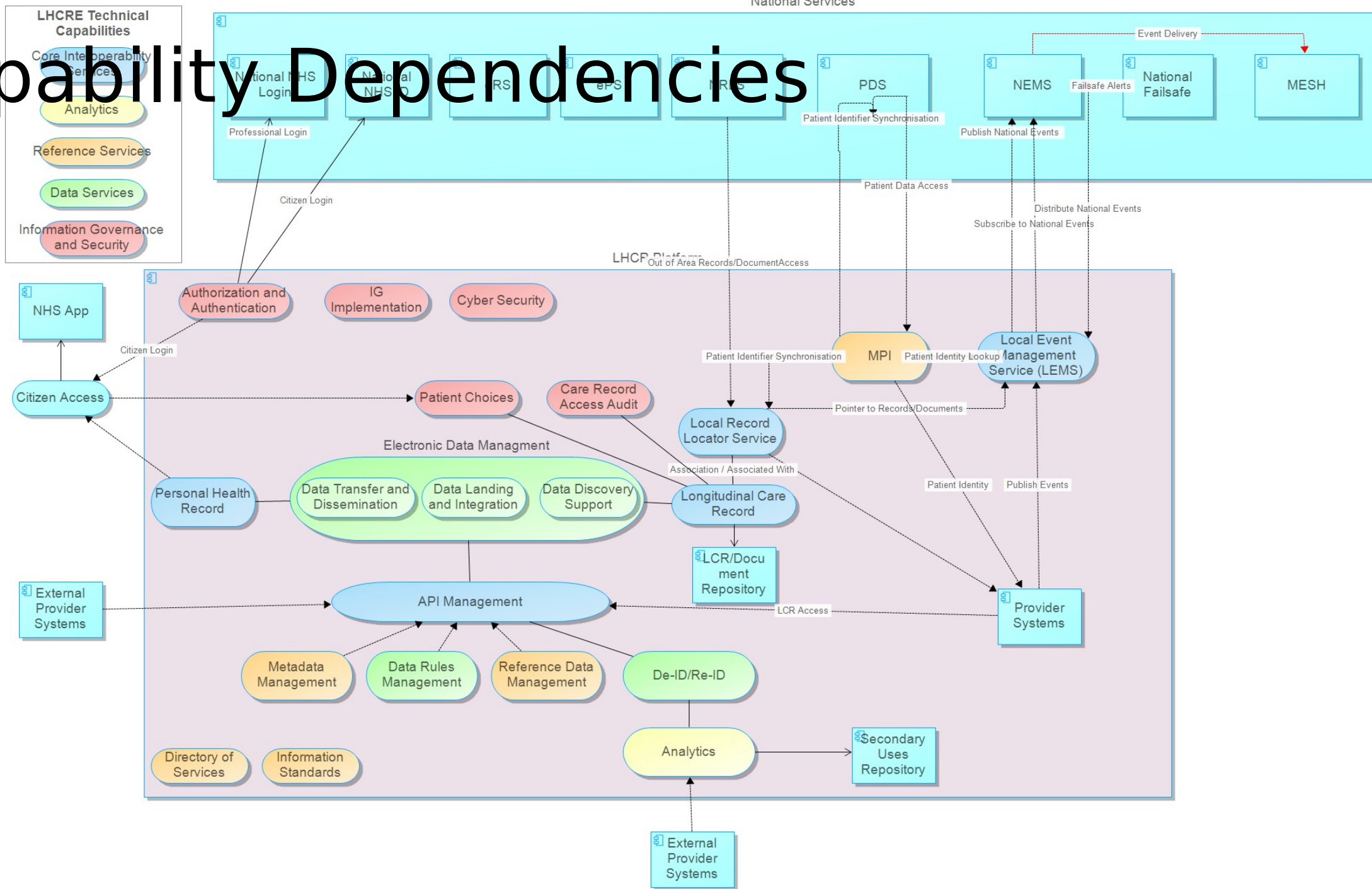

# LCR

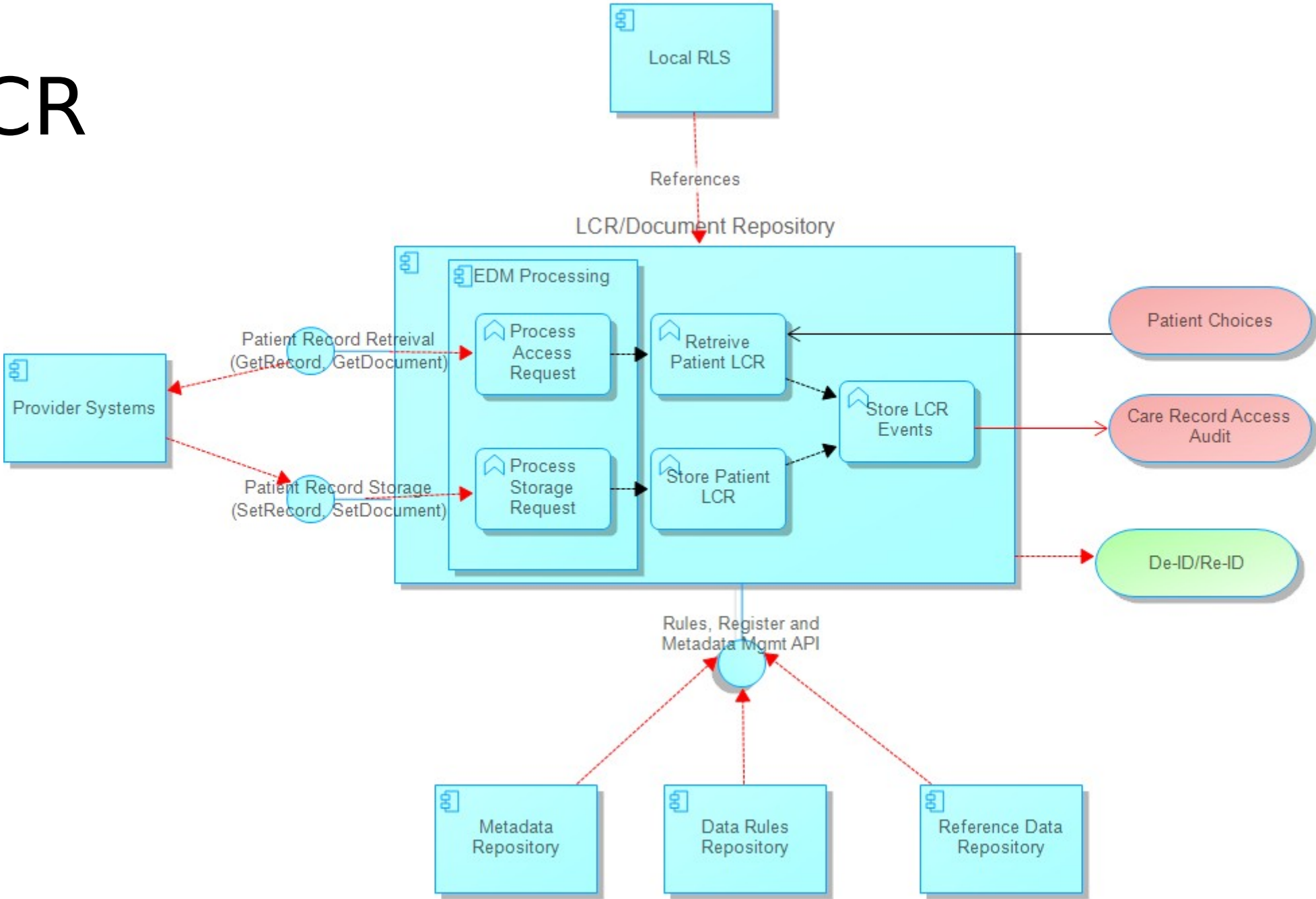

# Event Management

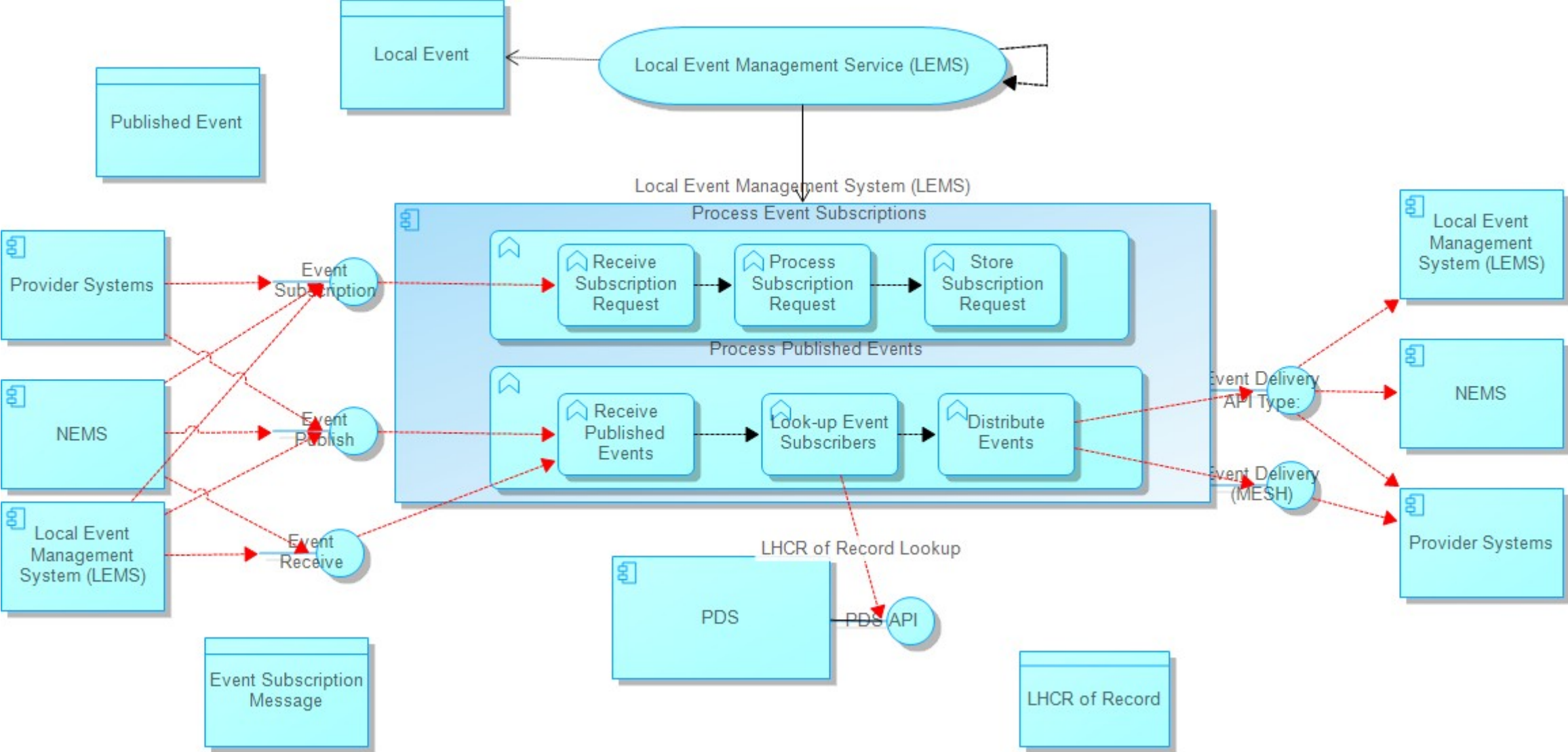

# RLS

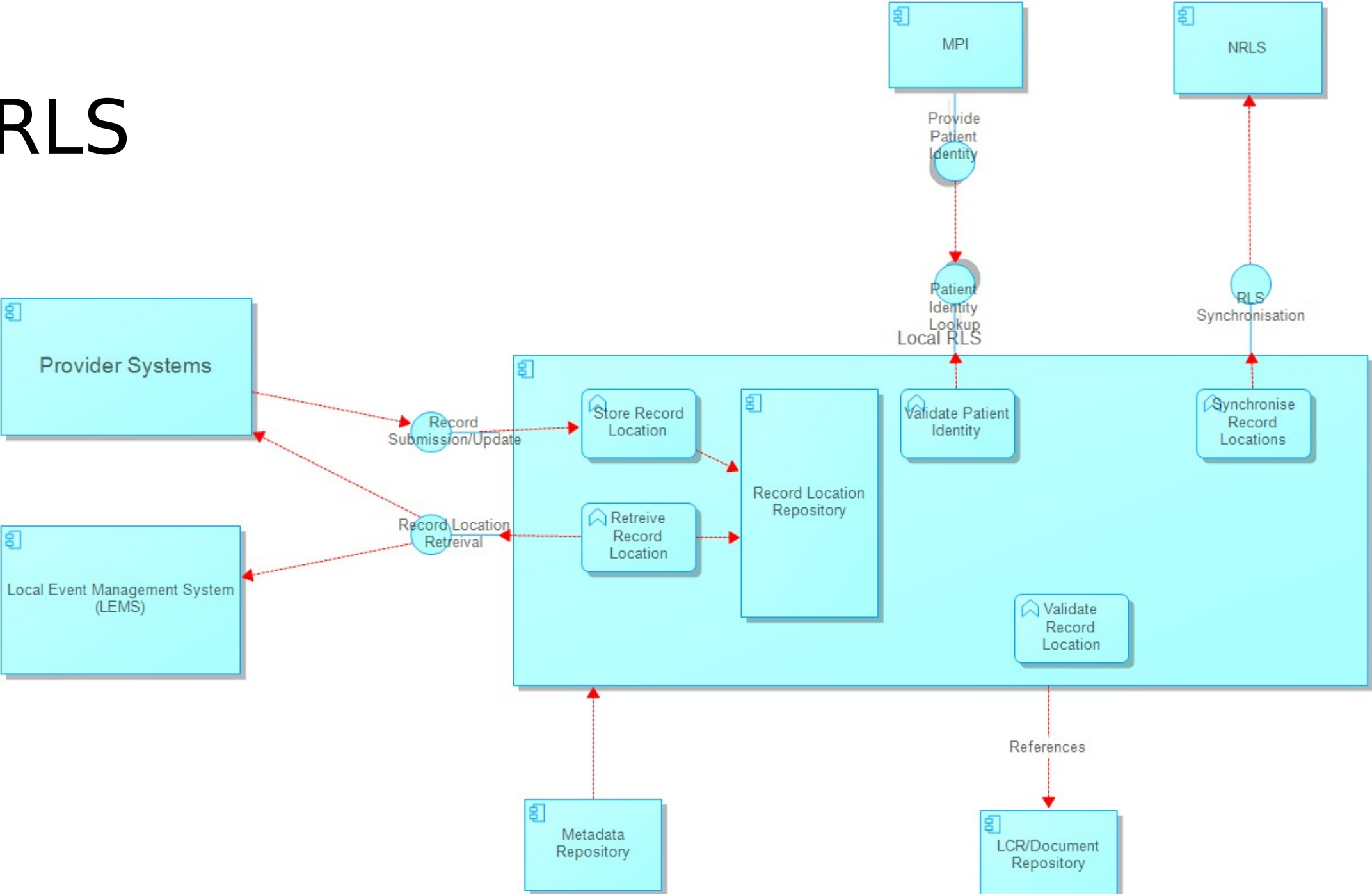

# MPI

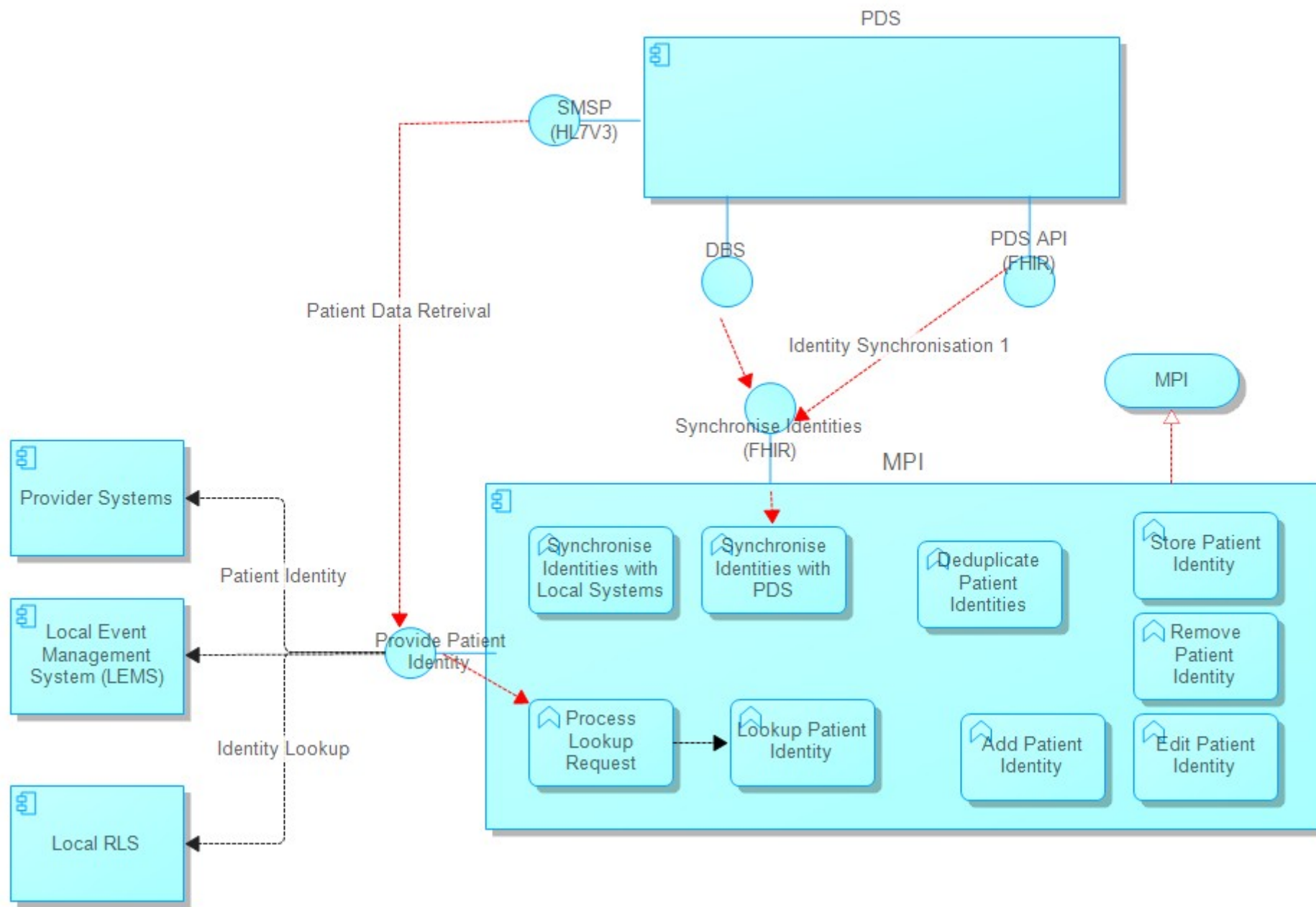

# Data Model (Segment)

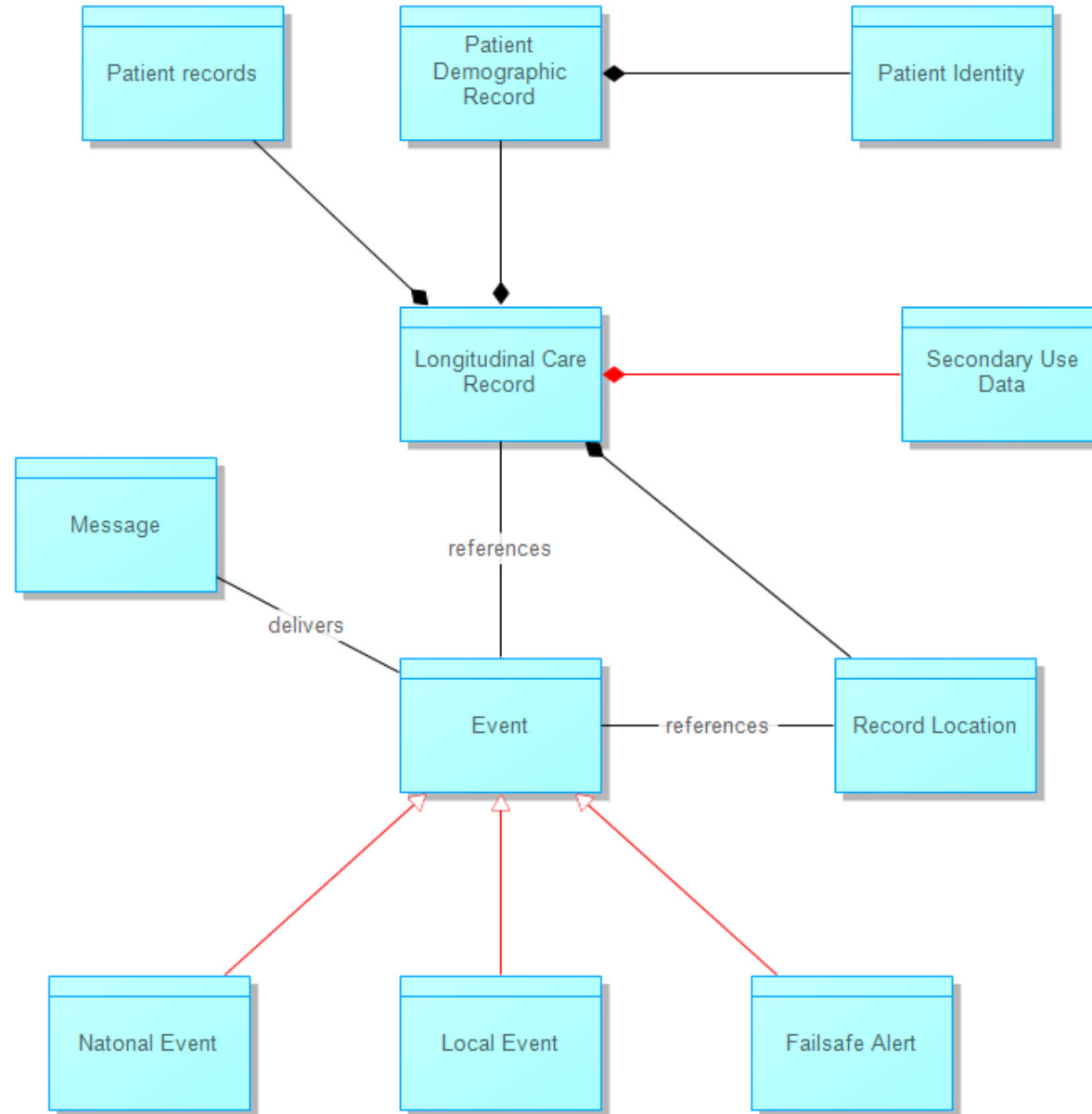

# LHCR Views

- Present logical views showing the major components (e.g. Data Management, Event Management, Record Location, Patient Identity) of the architecture and illustrating the primary interactions between the LHCR capabilities (see LHCR reference architecture). Also show how the solution will interoperate with other LHCRs in scenarios such as Unscheduled Out of Area treatment and Scheduled Direct Care, and how your architecture will provide interoperability with National Services (e.g. NRLS, PDS, NEMS).
- For each interaction indicate the mechanism to be implemented to achieve it e.g. Standards based API (FIHR), Bespoke interface, file transfer, batch upload, manual/physical media. Indicate the level of data processing (validation, standardisation, normalisation, aggregation etc.) required for each interaction.
- Provide a view which shows which major vendors/systems which will deliver each of the components within your architecture and indicate whether these are existing system or are expected to be new procurements.
- Provide a Programmatic View which shows the major capability increment milestones, with indicative dates and the level of interoperability/functionality achieved at each milestone.
- Describe the primary Risks, Assumptions, Issues and Dependencies associated with delivering the LHCR architecture. These should cover both technical and programmatic elements and should particularly highlight any perceived gaps in capability.
- Describe how areas such as Information Assurance, Consent, Authentication and Authorisation are handled.

# LHCR Logical Architectures

From bid documents.

# One London

## Proposed LHCRE Technical Architecture

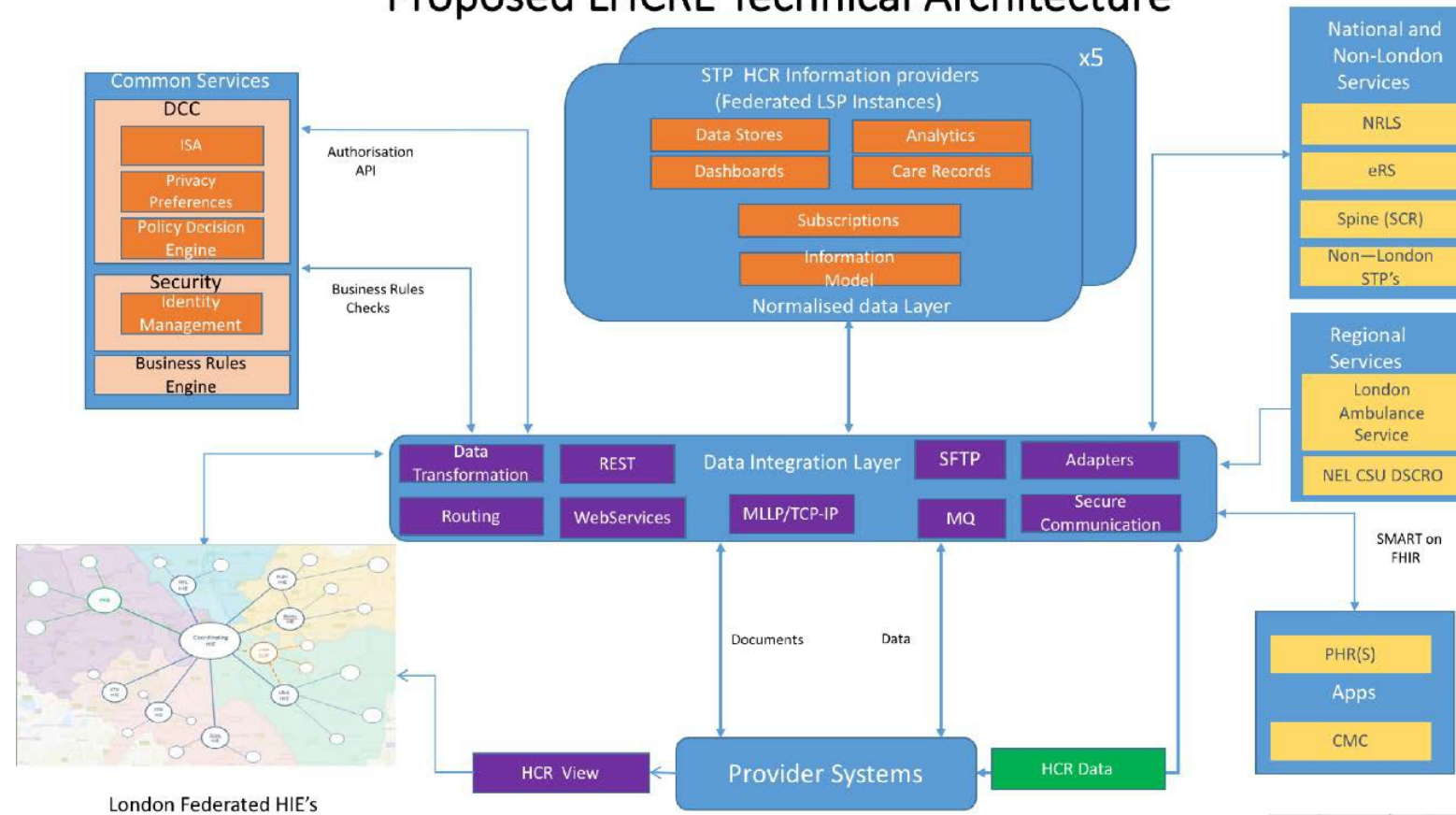

# Wessex

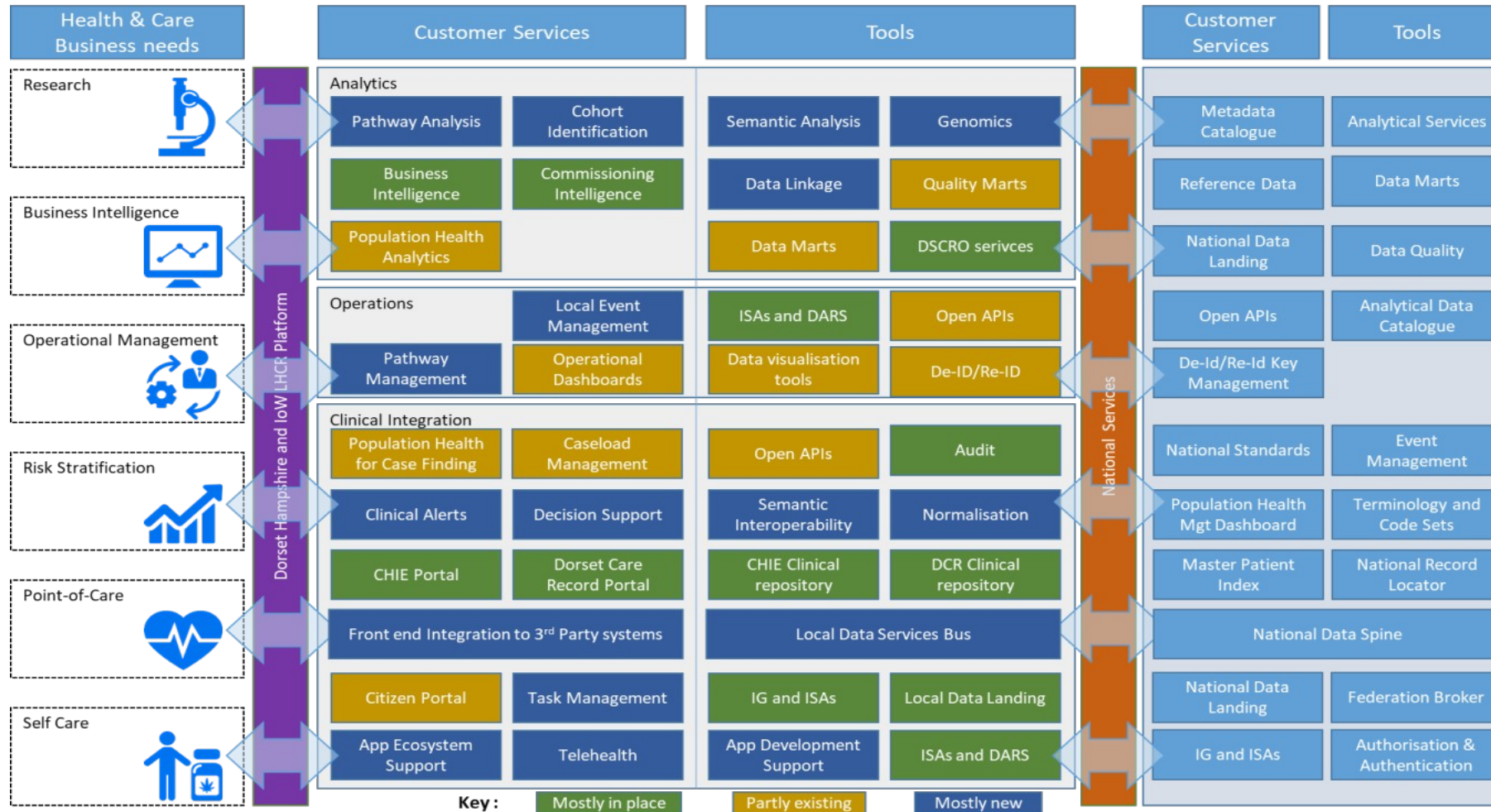

# Wessex

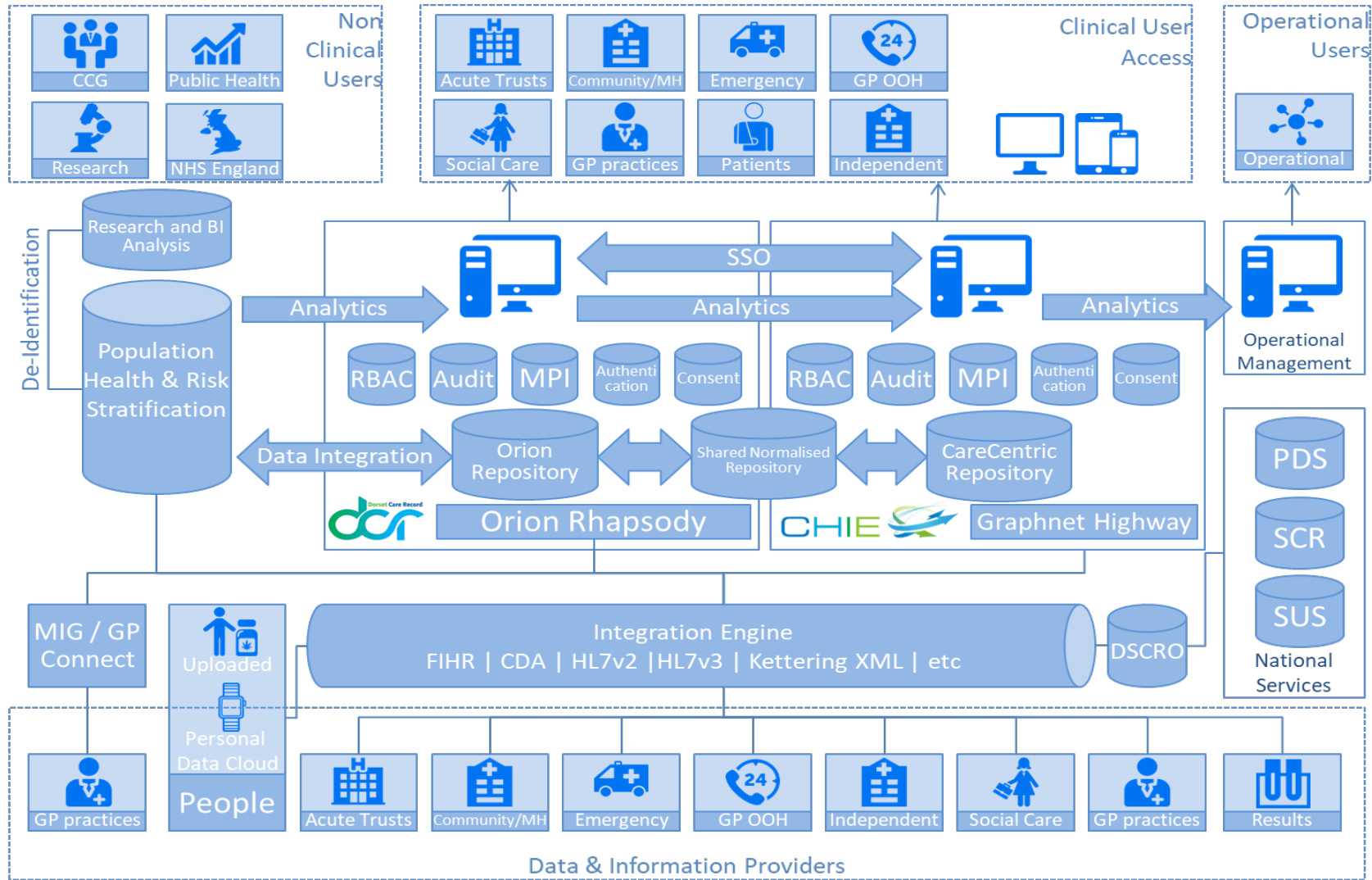

# Yorkshire

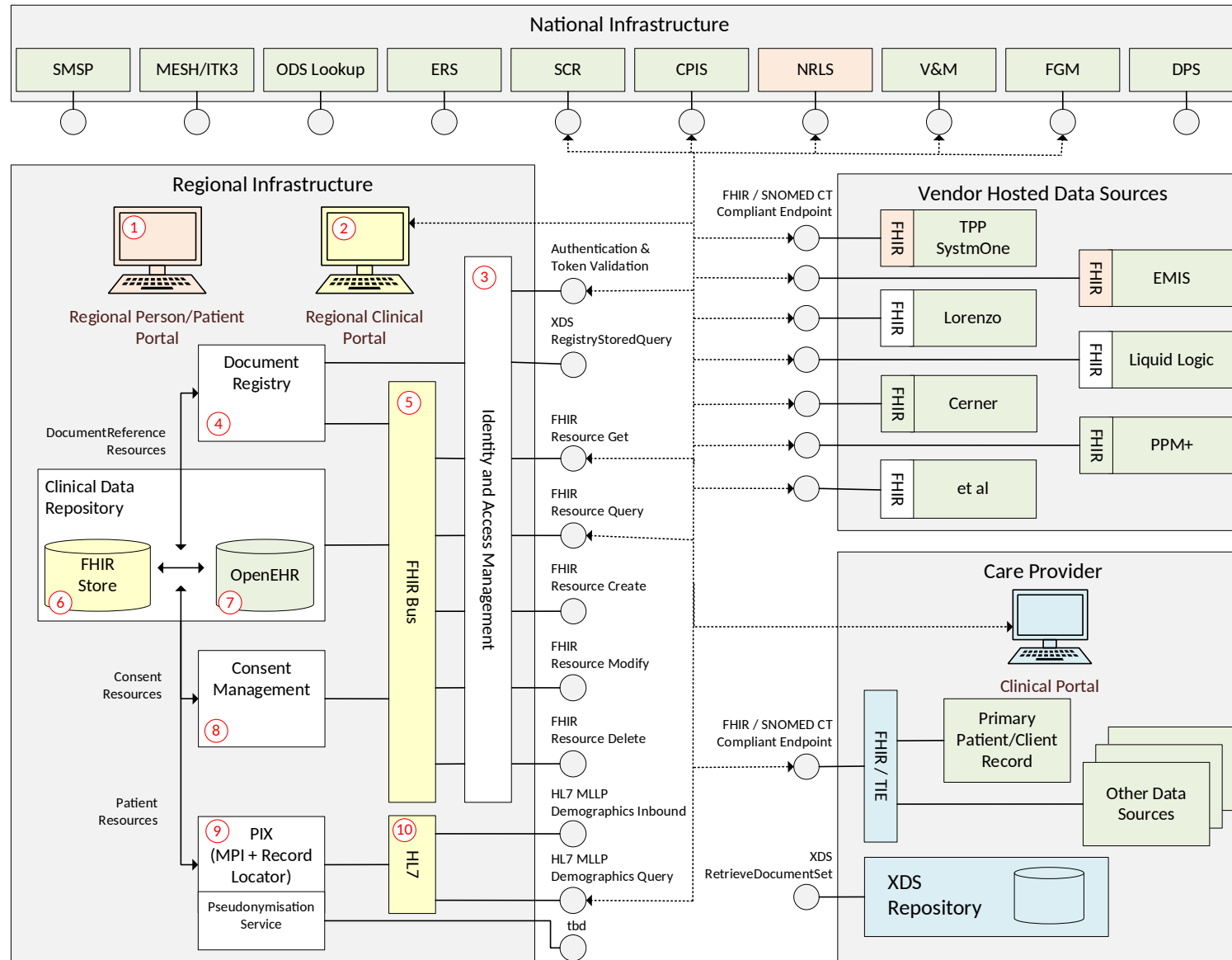

# Logical Architecture - Requirement

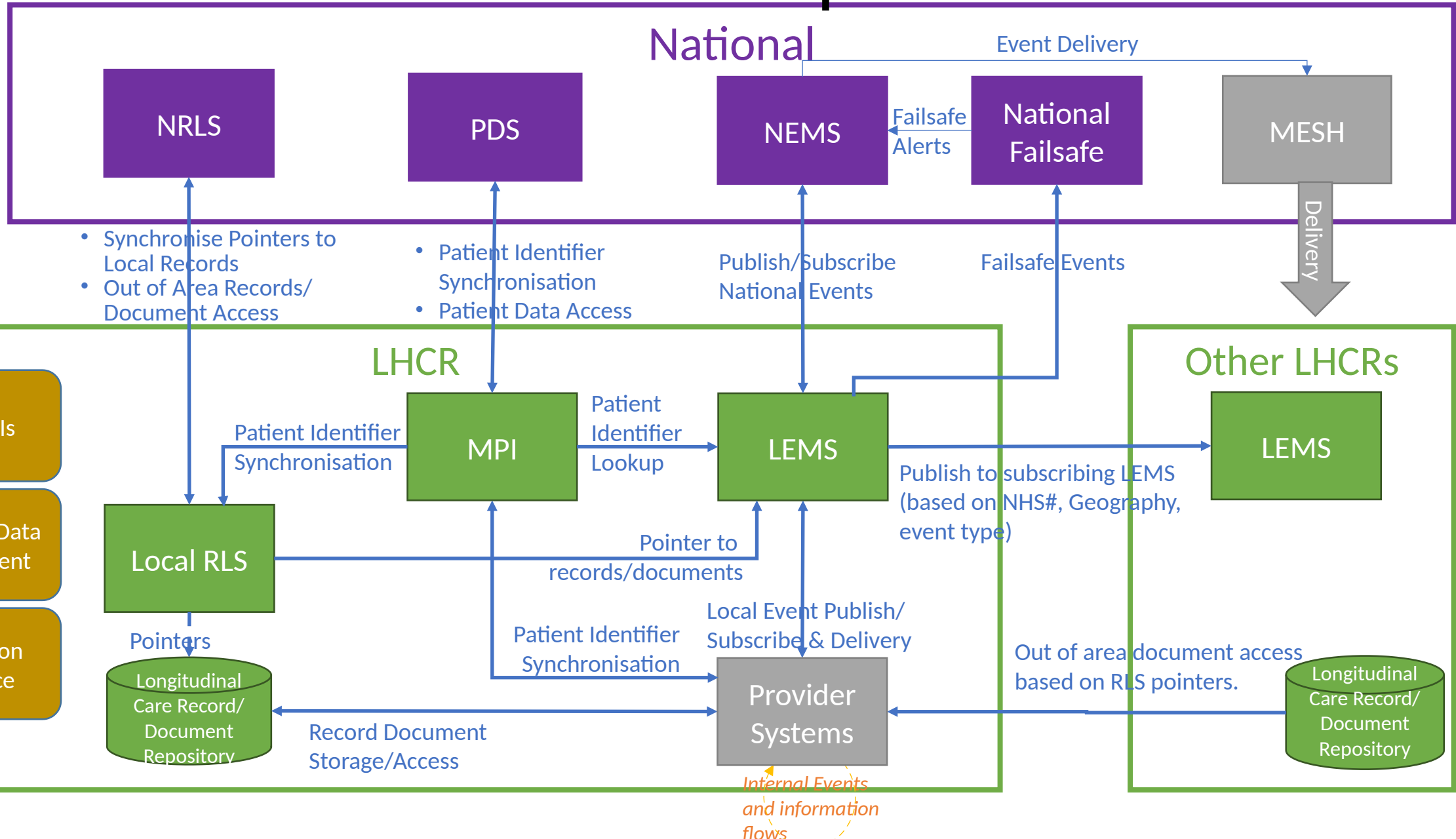

# Architecture Realization

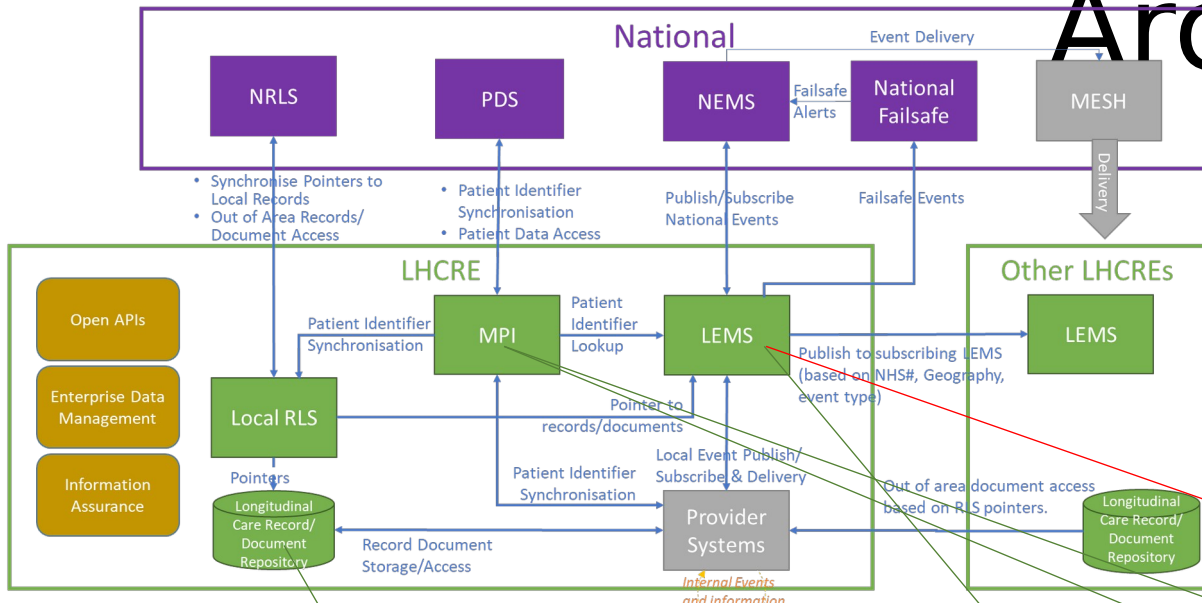

The Architecture can show the realization of the Technical Capabilities, Interfaces etc. by the LHCRs. This can highlight capability gaps, non-compliances and give an understanding of how each LHCR is going to deliver the requirement.

Capability Gap?

Yorkshire

Wessex

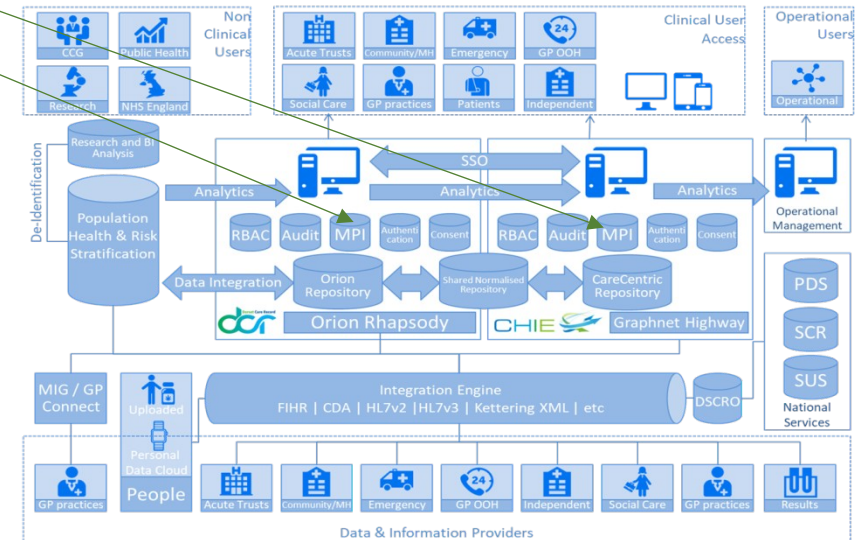
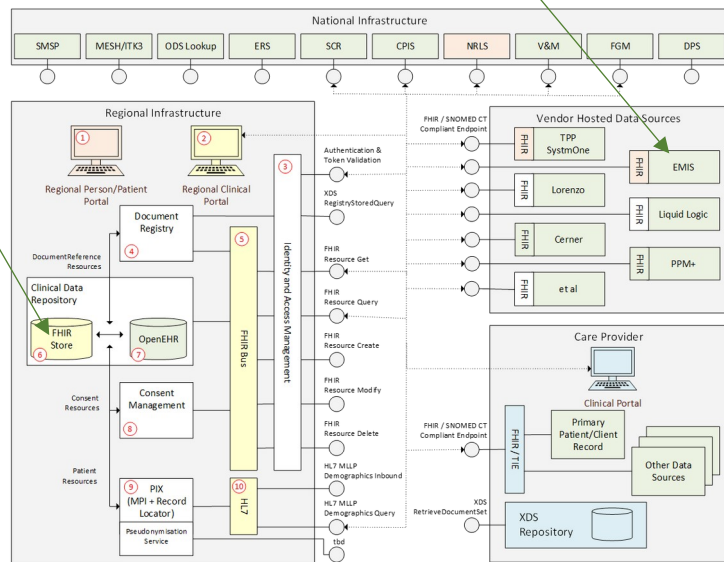

# LHCR Architecture Framework - draft

